

INDUSTRIAL CRANES  
NUCLEAR CRANES  
PORT CRANES  
**HEAVY-DUTY LIFT TRUCKS**  
SERVICE  
MACHINE TOOL SERVICE

**CONTAINER LIFT TRUCKS**

**KONECRANES**<sup>®</sup>  
Lifting Businesses<sup>™</sup>

**Empty 8 – 10 tons, laden 33 – 45 tons**  
**CONTAINER LIFT TRUCKS**  
**WITH HEART**









# TAKING CONTAINER HANDLING TO A HIGHER LEVEL

**Konecranes has a long history of working with leading container ports and terminals that are expert buyers and operators of container lift trucks. Our customers demand a lot of us, and we have a long track record of meeting their requirements year after year.**

## Empty container lift trucks

Empty containers are non-paying containers that have to be moved out of the way and brought back into play, with the greatest possible efficiency. Our empty container lift trucks offer a very fast total operating speed as a function of lifting, lowering and driving speed based on load-sensing hydraulics. The range has mid-mounted or rear-mounted cabins and excellent stability.

## Laden container lift trucks

Laden containers are paying containers that need to be moved with the right balance of efficiency and precision within the container handling process. Our laden container lift trucks offer a fast total operating speed (lifting + lowering + driving speed). The ratio of lifting capacity to truck size and length is best-in-class. These heavy-duty top-loaders are very stable and still rather compact.



**Made with heart  
in every detail**

**SMARTER  
WHERE IT  
MATTERS**

**Konecranes has been manufacturing, selling and supporting heavy-duty lift trucks for some 60 years. Buy a container lift truck from us today and you will get the latest technology, the lowest Total Cost of Ownership, and a lift truck made with heart.**

We claim the lowest Total Cost of Ownership with our container lift trucks, understood as an equation running over a time period of years as shown below. When you're shopping around the suppliers and comparing prices, our truck will probably not be the cheapest. But it will provide the best value over time.

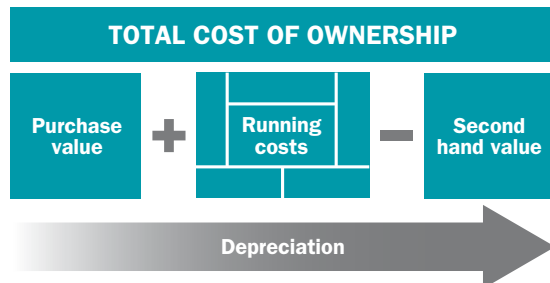

#### Close to you

We sell our lift trucks around the world in two main ways: directly via our own sales and service organizations in about ten countries, and indirectly via distributors in more than 80 countries. In both cases, our container lift trucks are fully supported with spare parts and personalized service. Konecranes has the widest service reach of any company in the lifting business. And our distributors are some of the most respected in the business.

#### Service made easy

To reduce lifetime running and maintenance costs we have extended the service interval of the engine by 500 hours, the gearbox by 1000 hours and the hydraulics by 4000 hours.

Our HLL ultra-fine filter system extends the hydraulic oil change interval from 4000 up to 12000 hours. In practice, you will use up to 80% less hydraulic oil than with a conventional hydraulic system.

#### GENUINE KONECRANES PARTS

Genuine Konecranes parts are the best protection for your investment. They pay off in truck performance and uptime.

#### PARTS ONLINE

> Easy to find, easy to buy

#### REAL-TIME SHIPMENT INFORMATION

> You know where your parts are

#### FAST DELIVERY

> Parts in stock are in your hands within 1–3 days

#### PROTECTION BOX

> All the filters you need, in one package



## LADEN CONTAINER LIFT TRUCKS

### 1 Reliable lifting

Lift masts adapted for laden container handling. Hoses and cables kept to a minimum for low maintenance costs and maximum uptime.

### 2 Single stacking spreader

Toplift handling of 20–40 ft containers, 45–53 ft containers are lifted in 40 ft position with the 4 twistlocks. There are 4 lift eyes for sling cargo, large sideshift, reach in & out, slew left & right and mechanical pile slope. Large sideshift, mechanical pile slope and optional hydraulic pile slope.

### 3 Maintenance-free brakes

Brakes with continuous oil cooling provide full braking power in every situation.

### 4 Powerful engine

Certified low-emission engine provides extra high torque at low revs, reduced fuel consumption and low noise levels. We offer a variety of engines for EU stage 2/3a/3b and EPA Tier 2/3/4i.

### 5 Excellent stability

Wide drive axle and long wheelbase: the two keys to excellent stability.

### 6 Heavy-duty box-type chassis

The strongest on the market. The foundation of long-lasting high performance.

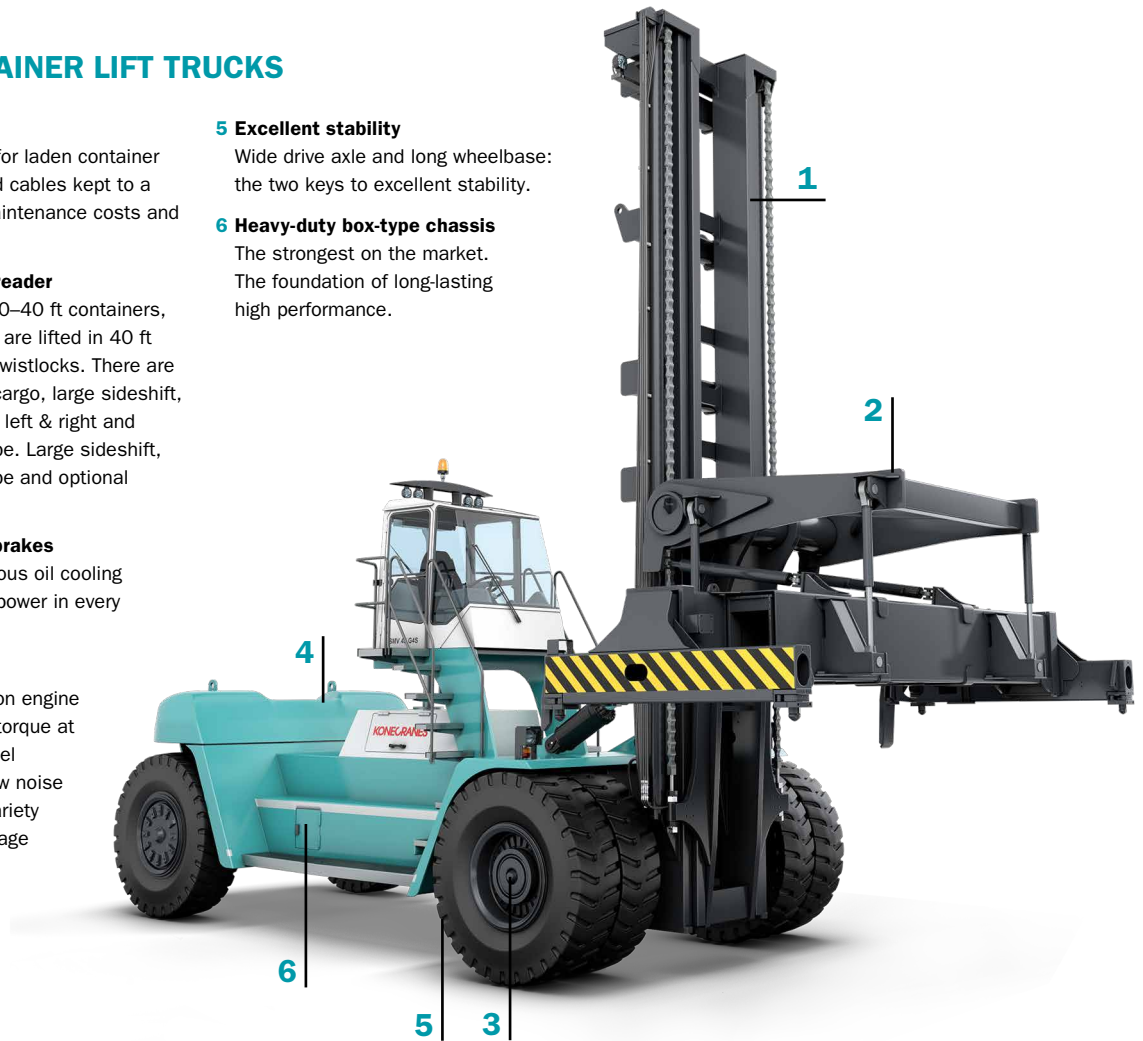

## EMPTY CONTAINER LIFT TRUCKS

### 1 Very fast lifting and lowering

The trucks can lift 8 containers high thanks to the wide mast: hoses and cables are kept to a minimum for low maintenance costs and maximum uptime. Heavy-duty mast and tilt cylinder solution for high stability and safety.

### 2 Intelligent Electronic Machine Control, EMC Master

Full monitoring of all the vital components and functions. Programmable settings. CanBus technology increases engine and transmission reliability.

### 3 ErgoCab, probably the best cabin on the market

Every detail has been carefully designed for comfort and safety. Controls, displays, ventilation and seating work to boost driver productivity. Excellent visibility in all directions.

### 4 Powerful engine

Certified low-emission engine provides extra high torque at low revs, reduced fuel consumption and low noise levels. We offer a variety of engines for EU stage 2/3a/3b and EPA Tier 2/3/4i.

### 5 Smart load-sensing hydraulics

They sense the load and adapt the lifting power to the weight of the load. The truck provides maximum power only when really needed, so it consumes less fuel while reducing emissions and noise.

### 6 Single and double stacking

Sidelift handling of 20–40 ft containers, 45–53 ft containers are lifted in 40 ft position with the twistlocks only. Large sideshift, mechanical pile slope and optional hydraulic pile slope. Single mode lifts up to 8 containers high. Double mode lifts up to 2-over-6.





Satisfied customers  
around the world

# OUT IN THE FIELD

Konecranes  
container lift  
trucks are hard  
at work around  
the world as an  
essential part of  
container port  
and intermodal  
operations.



Empty stacker, China

Empty stacker, Netherlands



Laden top-loader, United Kingdom



Laden top-loader, Saudi Arabia





Empty stacker, Indonesia



Laden top-loader, Australia



Empty stacker, Belgium

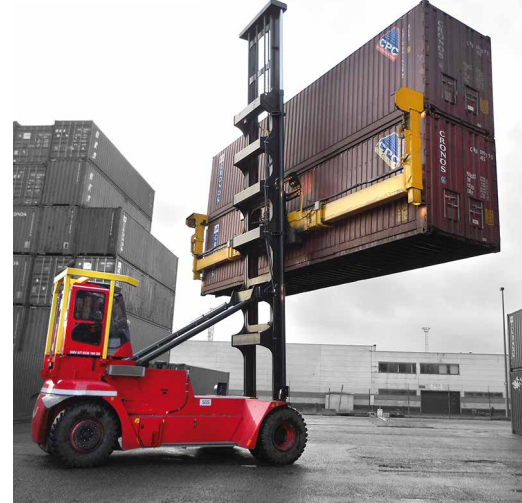

Empty stacker, Germany



Laden top-loader, USA



## ErgoCab

# TRULY SPACIOUS, REMARKABLE VISIBILITY

### Customized precisely as you need.

Step inside and you will find that ErgoCab is truly spacious: there is plenty of room for the driver and any extra equipment you might require. “Large” is the standard size. XL and XXL are available as options.

You will also be struck by the remarkable visibility. The windows are very large. There are no corner posts, and the roof cross-member is thin yet very strong. We have done everything possible to ensure clear sightlines to the key working areas, in front, to the sides and to the rear.

You can customize ErgoCab precisely as you require for your container handling operation. Select the joystick, steering wheel, driver’s seat and instrumentation that you need. The empty handlers have set cabin positions for optimized visibility: mid-mounted or rear-mounted on the chassis. The laden handlers have a forward-mounted cabin (3–4 high) or a raised, mid-mounted cabin (4–5 high).

#### 1 Remarkable visibility

Visibility is very difficult to measure objectively: you just know it when you see it. Sit down in ErgoCab, see what visibility from a lift truck cabin can be.

#### 2 Intelligent Electronic Machine Control

Our EMC Master system gives the driver real-time information on truck performance including full monitoring of the engine, transmission, hydraulics and joystick.

#### 3 Left armrest mini-steering options

Optional, ergonomic steering solutions that improve productivity.

#### 4 Ergonomic instrumentation

Whatever extra equipment you need, we can install it as part of an ergonomic instrumentation layout. ErgoCab is truly spacious.

#### 5 Comfort

An excellent seat with compressor suspension, powerful cabin heating and ventilation, air conditioning – the driver is provided with every possible comfort.

#### 6 Joystick control

Available with a hydraulic joystick or electronic joystick (optional).

#### 3 Left armrest mini-steering options



Lever steering with return





Mini-wheel steering

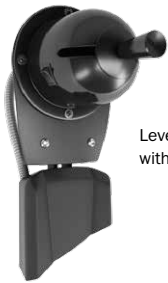

Lever steering without return

**6** Right armrest joystick options



Hydraulic servo joystick



Electronic servo joystick

## A world of options

# BOOSTING SAFETY AND EFFICIENCY

**Konecranes invests significantly in container lift truck R&D to be the first to offer new technologies that improve performance and safety. We also ensure that our container lift trucks are fully compliant with emissions regulations, anticipating their evolution as a normal part of our product development process.**

### Emissions-compliant diesel engines

We offer a wide range of powerful Volvo, Scania and Cummins engines certified according to EU stage 2/3a/3b and US EPA Tier 2/3/4i. For EU stage 2/3a and US EPA Tier 2/3 compliance we can offer additional 2-way catalyzers or particle filters (including a catalyzer) to reduce exhaust emissions even further.

### EMC Master

Our Intelligent Electronic Machine Control system, EMC Master, provides the following functions as standard:

- Full truck monitoring
- ECO-Drive and fuel management
- Productivity counter management

The following functions are optional:

- Electronic weight scale
- Mini-wheel steering
- Mini-lever steering
- Auto engine shut-down
- Auto parking brake
- Auto tilt-to-zero of lift mast
- Data logging of alarms and errors
- Remote Access Service (via GSM)
- Drive speed limitation (unloaded/loaded)
- Driver log-in (20 drivers)

### NearGuard warning system

The award-winning NearGuard warning system is based on Radio Frequency Identification Detection (RFID) technology. The system consists of 2–4 receivers mounted on the lift truck and RFID tags attached to obstacles and/or employees working in the lift truck's operating area. When the lift truck is driven in close proximity to a tagged obstacle or employee, the driver sees a flashing warning indicator on the EMC control system's color display. NearGuard brings a powerful new dimension to lift truck safety and infrastructure protection.

### Tire pressure monitor

Under-inflated tires can increase fuel consumption by as much as 15% while impairing stability and drivability. Our tire pressure monitor makes it easy to keep your lift truck tires properly inflated. It's installed in minutes. If you combine it with the drive speed limitation provided by EMC Master you can extend the life of your tires even further.

### Fire alarm and suppression system

We offer an effective fire alarm and suppression system that can be activated either manually or automatically. When the lift truck is in use, the system discharges in three ways: manually from inside the cabin; manually from outside via a mudguard trigger; automatically by sensors in the engine compartment. When the truck is not in use, i.e. when the master power switch is turned off, the system discharges automatically when the fire alarm goes off.

### Other safety options

- Parking Distance Control (PDC): with sensors for driving in reverse
- Breath Analyzer: an alcohol test unit which requires the driver to take a breath test before starting the lift truck
- Camera Supervision System: can be mounted as a reversing camera on the rear of the lift truck, or as a forward camera mounted on e.g. the mast

1 EMC Master monitor

2 TURBO 2 air filter for engine, 2-stage cyclone heavy-duty filter with indicator

3 Tire pressure monitor

4 Additional lamps on console, choose between Halogen, Xenon and LED lamps. You can have up to 10 extra lamps

5 Reverse camera display

6 Choose between hydraulic servo and electronic servo joystick

**For a complete list of standard vs. optional equipment, please see page 14.**

1



2



3



4



5







## Getting the job done right

# ATTACHMENTS

### For empty container handling



#### ELME 588-TB single stacking spreader

Telescopic sidelift spreader for empty ISO containers with capacity up to 9 tons. Strong and well-proven single beam spreader design, two floating heads ( $\pm 70$  mm) with hydraulic operation and mechanical safety locking. Hydraulic extension with 2 cylinders (20–40 ft), large sideshift ( $\pm 300$  mm) with 1 cylinder. Spreader side tilt with floating end-posts (stroke 200 mm / mechanical pile slope). Hydraulic pile slope ( $\pm 6$  deg) and longer sideshift ( $\pm 600$  mm) are optional. Four strong LED work lamps (top-bottom/left-right).

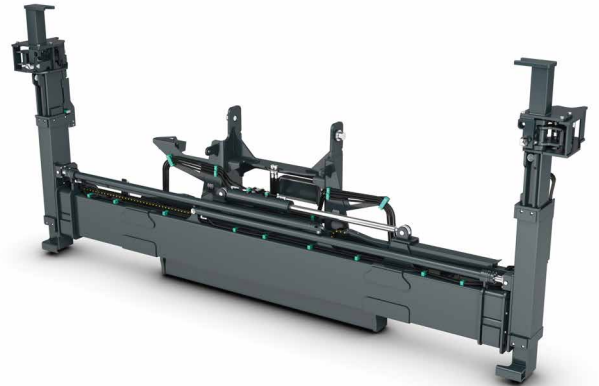

#### ELME 584-LB double stacking spreader

Telescopic sidelift spreader for single and double stacking of empty ISO containers with capacity up to 10 tons. Strong and well-proven single beam spreader design, with two fixed horizontal lifting hooks and two hydraulic side clamps with safety locking and sensors. Same extension 20–40 ft, large sideshift, side tilt with vertical floating end-posts (mechanical pile slope). Hydraulic pile slope ( $\pm 6$  deg) and longer sideshift ( $\pm 600$  mm) are optional. Four strong LED work lamps.

### For laden container handling

#### ELME 818 gantry-type spreader

Telescopic toplift spreader for laden ISO containers with capacity up to 45 tons. Strong and well-proven parallel double beam spreader design, pendular twistlock system ( $\pm 10$  mm) with hydraulic operation and mechanical safety locking. Hydraulic cylinder extension (20–40 ft), large sideshift ( $\pm 200$  mm), reach in/out (0–240 mm) and slew left/right ( $\pm 6$  deg). Spreader side tilt with stroke of  $\pm 5$  deg (MPS mechanical pile slope) and 4 lift eyes included for slings (45 tons). Hydraulic pile slope HPS is optional ( $\pm 6$  deg). The spreader frame and the end beams are of strong heavy-duty design. Weight 818-MPS/HPS = appr. 7.1 tons.





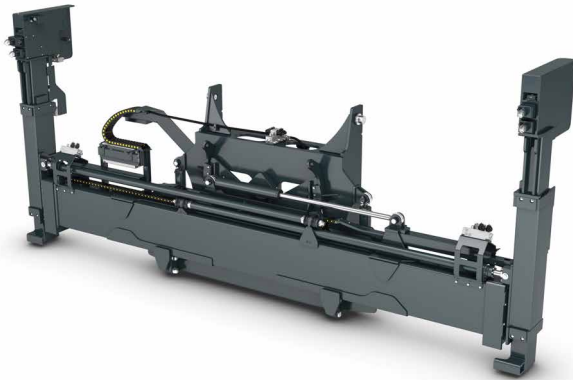

#### **ELME 582-LS double stacking spreader**

Telescopic sidelif spreader for single and double stacking of empty ISO containers with capacity up to 10 tons. Strong and well-proven single beam spreader design, with two pairs of horizontal twistlocks and safety locking with sensors. The lower twistlock pair lifts the lower container and the upper twistlock pair lifts the upper container, each twistlock pair with safety locking and sensors. The upper pair has a retract stroke of 110 mm (4,3") for alignment of the upper container. Same extension 20–40 ft, large sideshift, side tilt with vertical floating end-posts. Hydraulic pile slope ( $\pm 6$  deg) and longer sideshift ( $\pm 600$  mm) are optional. Four strong LED work lamps.



# EQUIPMENT

For all Konecranes container lift trucks

## STANDARD EQUIPMENT

### TRUCK BODY

#### Box-type chassis

- Strong box profiles and cross-members
- Thick steel plate reinforcement, both front and rear
- Empty handlers: safe, ergonomic access steps and hand rails LHS
- Empty handlers: extra high tilt cylinder fixtures on mast and rear of chassis
- Empty handlers: lifting eyes, front in mast and rear in steer axle stops
- Laden handlers: safe, ergonomic access steps and hand rails LHS+RHS
- Laden handlers: high tilt cylinder fixtures on mast and mid of chassis
- Laden handlers: lifting eyes, front in mast and rear on top of counter weight

#### Standard counter weights and stability

- Empty handlers: raised 875 mm / middle of chassis position (ECB 80)
- Empty handlers: low / rear of chassis position (ECB 90–100)
- Laden handlers: low / front of chassis position (37 G3–52 G4)
- Laden handlers: raised 840 mm / middle of chassis position (37 G4S–52 G5S)
- Steel mudguards

#### Standard colors:

- Chassis, tanks, mudguards and rear: seagreen NCS S2555 B30G
- Mast, carriage, spreader and axles: black RAL 7021
- Cabin and engine hood: light grey RAL 70335

### STEERING AXLE

- Smooth power steering with double-acting cylinder
- Wide steering angles providing small turning radius

### DRIVE AXLE

- Empty handlers: Kessler D81
- Laden handlers: Kessler D102 (37G–45G) / Kessler D106 (52G)
- Wide axles with 2-stage hub reduction and differential
- Oil-cooled, maintenance-free wet disc brakes

### DIESEL ENGINE

See technical info chart, certified for EU stage 2 / EPA Tier 2

- Certified for EU stage 2, 3A, 3B / EPA Tier 2, 3, 4i
- Low-emission
- Clean, powerful, fuel-efficient with CanBus controls

Engine air filter, 2-stage type

### TRANSMISSION

- Empty handlers: DANA TE-17 (3+3 gears)
- Laden handlers: DANA TE-27 (4+4 gears)
- Fully-automatic, softshift
- Torque converter, smooth powershift, declutch, reverse protection, CanBus controls

### COOLING SYSTEM

- Tropical, multi-radiator
- Radiators for engine water, air for intercooler, oil for transmission
- Oil cooling / flushing for brakes

### HYDRAULIC SYSTEM

- Load-sensing, power-on-demand
- Smooth, accurate, high-speed lifting and lowering
- Variable piston pumps with intelligent control
- Leak-free ORFS couplings (O-ring) for entire truck
- Shock-absorbing lift mast accumulator (models ECB 90–100)
- Large oil tanks with return line filters (12 microns)

### ELECTRICAL SYSTEM 24V

Alternator standard size 55–110 Ah (see engine chart)

## OPTIONAL EQUIPMENT

### TRUCK BODY

- Extra counter weights for increased stability
- Empty handlers ECB 90–100: raised rear cabin position, 1200 mm higher than standard (cab roof 5100 mm)
- Laden handlers 37 G3/4, 45 G3/4, 52 G3/4: raised front cabin position, 400 or 700 mm higher than standard
- Different mud flap models, front and rear
- Extra chassis mirrors
- Slip protection: strips or aluminum plates
- Fire extinguisher on truck body or inside cabin
- Fire fighting system for driveline compartment (semi-automatic)
- Galvanized storage boxes with lid (on bottom step)
- Custom colour painting, stickers, customer logos

### STEERING AXLE

- Wheel nut protection and steering cylinder spacers

### DRIVE AXLE

- Laden handlers 37G–45G: Kessler D106 extra strength

### DIESEL ENGINE

- Empty handlers: Volvo and Cummins (147–185 kW / 700–1180 Nm)
- Laden handlers: Volvo, Scania and Cummins (256–294 kW / 1640–2157 Nm)
- Certified for EU stage 2, 3A, 3B / EPA Tier 2, 3, 4i
- Low-emission
- Clean, powerful, fuel-efficient with CanBus controls
- Engine air filter Turbo II, 2-stage cyclone type

### TRANSMISSION

- Empty handlers: ZF 3WG-171 (3+3 gears), ZF 4WG-191 (4+3 gears)
- Laden handlers: DANA TE-32 (4+4 gears), ZF 4WG-261 (4+3 gears)
- Fully-automatic, softshift
- Torque converter, smooth powershift, declutch, reverse protection, CanBus controls

### COOLING SYSTEM

- Extra radiator / cooling circuit for hydraulic system

### HYDRAULIC SYSTEM

- Shock-absorbing lift mast accumulator (models ECB 80 / 37G–52G)
- High-pressure filters (12 um)
- HLL hydraulic longlife filters (3 um)
- Hydraulic oil cooling circuit for working hydraulics

### ELECTRICAL SYSTEM 24V

- Bigger alternator 80–150 Ah (see engine chart)
- Reverse alarm (beeping)
- NearGuard RFID warning system (receiver and transmitters)
- NATO starting aid contact
- Built-in battery charger
- Pre-heater for engine, transmission, hydraulics and cabin
- Power connections 400V/3-phase for multiple preheaters



## STANDARD EQUIPMENT

### LIGHTS

Full road lighting LED: blinkers, brake lights, tail lights, position lights  
2 x LED front lights on mudguard  
2 x LED reverse lights on cabin (ECB 80–100) / counter weight (37G–52G)  
2 x LED work lights in lift mast  
4 x LED work lights on spreader (ECB 80–100)  
2 x LED work lights on spreader (37G–52 G)

### CABIN

ErgoCab size large (L), two doors  
L x W x H = 1580 x 1450 x 1620 mm  
Spacious, comfortable, excellent ergonomics  
Excellent visibility: no front corner posts

Powerful heating and cooling unit

Electrical connection 24V (1 x in cab roof RHS)

Three windshield wipers/washers  
Adjustable seat, seat belt, steering wheel

Joystick (hydraulic servo)

## OPTIONAL EQUIPMENT

### LIGHTS

Lamp console on cabin roof: up to 10 work lamps and 2 warning beacons  
Extra work lights: Halogen (70 W), Xenon (3250 Lum), or LED (2900 Lum)  
LED warning beacons: cabin roof, lamp console, mast, rear or other position  
LED strobe warning flash lights: front, rear or other position

### CABIN

ErgoCab size extra-large (XL)  
L x W x H = 1655 x 1450 x 1720 mm (longer and higher)

Extra mirrors inside cabin  
Reverse and front cameras with 6.7" display (MOTEC)  
Air conditioning or climate control unit (stepless fan speed)  
Extra electric cabin heater 220V (DEFA)  
Extra diesel-powered cabin heater (Webasto)  
Extra electrical connections 24V (cab roof or front panel RHS)  
Extra electrical connections 12V (cab roof or front panel RHS)  
Interval wiper speed switches: front, roof and rear windows  
Pneumatic compressor horn: extra button or on joystick  
Various compressor seats: BEGE, ISRI, Grammer  
Additional seat dampening: single or double  
Two-point or three-point seat belt  
Seat heating  
Extra trainer's seat, leather, fully-foldable LHS  
Joystick (electronic servo / auto throttle)  
Tire pressure monitor: cabin display, 6 tire sensors  
Sun blinds: front, roof or rear windows, fixed or adjustable  
Alcohol lock / start-up prohibitor (Draeger)  
Reverse alarm (beeping)  
Universal mounting system for RHS for A4/A5 writing pad, keyboard, computer monitor, com radio and reading lamp  
CD player / radio / MP3 player with dual loudspeakers

### MACHINE CONTROL

Intelligent machine control with EMC Master Display: MD3, size 3.5"  
Monitoring of engine, transmission, hydraulic system, service, hydraulic joystick, counters and info  
EMC 106: Monitoring (diagnostics/parameters/settings)  
EMC 123: ECO-Drive (fuel consumption, saving, settings)  
EMC 125: DATA-Log (storage of alarms and errors)

### MACHINE CONTROL

Display: MDL2, size 6.5"

EMC 102: Lever steering (with spring return to zero)  
EMC 103: Lever steering (no spring return to zero)  
EMC 104: Mini-wheel steering (speed progressive steer function)  
EMC 105: Mini-wheel steering (not progressive steer function)  
EMC 107: Electronic weight scale (resolution 0.1 ton)  
EMC 112: Auto engine shut-down timer  
EMC 114: Electronic servo joystick (auto throttle)  
EMC 122: Drive speed settings (on/off, programmable)  
EMC 124: Driver log-in (up to 20 drivers)  
EMC 126: GSM remote access  
NearGuard RFID warning system (receiver and transmitters)

### LIFTING MASTS

High-speed, wide, high stability  
Only two hydraulic hoses and one cable over top of mast

### LIFTING MASTS

### SPREADERS

Empty handlers: for single lifting ELME 588TB with 2 vertical twistlocks (ECB 80–90)  
20–40 ft stops  
MPS Mechanical Pile Slope 200 mm  
Sideshift ±300 mm  
Empty handlers: for double lifting ELME 584LB with 2 side lifting hooks + 2 side clamps (ECB 100 DS)  
20 ft and 40 ft stops  
MPS Mechanical Pile Slope 200 mm  
Sideshift ±300 mm  
Laden handling: ELME 818 with 4 vertical floating twistlocks  
20–40 ft stops  
MPS Mechanical Pile Slope ±5 deg  
Sideshift ±200 mm  
Reach in/out 0–240 mm  
Slewing ±6 deg

### SPREADERS

Extra electrical stops at B7, 30 ft (only single stacking)  
HPS Hydraulic Pile Slope ±6 deg  
Larger sideshift ±600 mm (ECB 90–100)  
Empty handlers: ELME 582LS with 2+2 side twistlocks (ECB 100 DS)  
HPS Hydraulic Pile Slope ±6 deg  
Extra stops at B7, 30 ft  
Larger sideshift ±400 mm

### SERVICE AND PARTS

Regular warranty 12 months / 2000 hours

### SERVICE AND PARTS

Extended warranty on truck and driveline (18–36 months / 3000–6000 hours)  
Spare tires, rims, complete wheels: various brands  
Spare part kits: basic, extended, special  
Complete filter kits: 2000 hours up to 8000 hours

# DRIVELINES

## Empty container lift trucks 8–10 tons

MODEL		SMV 3-6 / ECB 80			SMV 3-8 /ECB 80-90-100 DS			
Engine	Units							
Make		Volvo	Volvo	Volvo	Volvo	Volvo	Cummins	Volvo
Model		TAD-620-VE	TAD-660-VE	TAD-561-VE	TAD-722-VE	TAD-760-VE	QSB-6,7-C260	TAD-762-VE
Emission approval, EU / US		St 2 / Tier 2	St 3a / Tier 3	St 3b / Tier 4i	St 2 / Tier 2	St 3a / Tier 3	St 3a / Tier 3	St 3b / Tier 4i
Power / max speed (ISO 3046)	kW/rpm	147 / 2300	147 / 2300	155 / 2300	180 / 2300	184 / 2300	201 / 2300	185 / 2300
Torque @ speed (ISO 3046)	Nm/rpm	700 / 1500	800 / 1600	820 / 1200	1050 / 1400	1100 / 1500	990 / 1500	1180 / 1250
Displacement / cylinders	L/-	5.7 / 6-cyl	5.7 / 6-cyl	4.8 / 4-cyl	7.2 / 6-cyl	7.2 / 6-cyl	6.7 / 6-cyl	7.2 / 6-cyl
Alternator power / capacity	W/Amp	1540 / 55	2240 / 80	2800 / 100	1540 / 55	2240 / 80	1960 / 70	2800 / 100
Fuel consumption (normal)	L/hour	7-10	6-10	5-10	8-12	7-12	7-12	7-12
Transmission (make / model)		DANA TE-17	DANA TE-17	ZF 3WG-171	DANA TE-17	DANA TE-17	DANA TE-17	ZF 4WG-191

MODEL		SMV 3-6 / ECB 80			SMV 3-8 /ECB 80-90-100 DS	
Transmission	Units					
Make		DANA	ZF	ZF	DANA	ZF
Model		TE-17300	3WG-171	4WG-191	TE-17300	4WG-191
Gear shift type		Automatic	Automatic	Automatic	Automatic	Automatic
No. of gears (fwd / rev)	No.	3 / 3	3 / 3	3 / 3	3 / 3	4 / 3
Power rating (max)	kW	200	180	200	200	200

## Laden container lift trucks 33–45 tons

MODEL		SMV 37 G3-52 G5S							
Engine	Units								
Make		Volvo	Scania	Scania	Cummins	Volvo	Scania	Volvo	Scania
Model		TAD-1340-VE	DC-13-074	DC-13-076	QSM-11-C335	TAD-1360-VE	DC-13-081	TAD-1361-VE	DC-13-077
Emission approval, EU / US		St 2 / Tier 2	St 2 / Tier 2	St 3a / Tier 3	St 3a / Tier 3	St 3b / Tier 4i	St 3b / Tier 4i	St 3b / Tier 4i	St 3b / Tier 4i
Power / max speed (ISO 3046)	kW/rpm	256 / 2100	257 / 2100	257 / 2100	272 / 2100	256 / 1900	257 / 2100	285 / 1900	294 / 2100
Torque @ speed (ISO 3046)	Nm/rpm	1770 / 1250	1950 / 1200	1640 / 1400	1674 / 1000	1740 / 1200	1950 / 1200	1940 / 1000	2157 / 1200
Displacement / cylinders	L/-	12.8 / 6-cyl	12.7 / 6-cyl	12.7 / 6-cyl	10.8 / 6-cyl	12.8 / 6-cyl	12.7 / 6-cyl	12.8 / 6-cyl	12.7 / 6-cyl
Alternator power / capacity	W/Amp	3080 / 110	2800 / 100	2800 / 100	1960 / 70	3080 / 110	2800 / 100	3080 / 110	2800 / 100
Fuel consumption (normal)	L/hour	12-18	12-18	12-18	12-18	12-18	12-18	12-18	12-18
Transmission (make / model)		DANA TE-27	DANA TE-27	DANA TE-27	DANA TE-27	DANA TE-27 (opt. ZF 4WG-261)	DANA TE-27 (opt. ZF 4WG-261)	DANA TE-32	DANA TE-32

MODEL		SMV 37 G3-52 G5S			
Transmission	Units				
Make		DANA	ZF	DANA	ZF
Model		TE-27400	4WG-261	TE-32400	4WG-311
Gear shift type		Automatic	Automatic	Automatic	Automatic
No. of gears (fwd / rev)	No.	4 / 4	4 / 3	4 / 4	4 / 3
Power rating (max)	kW	270	280	325	330



## Empty container handlers

**Single stacking**  
3-6 high  
up to 8 tons



**Single stacking**  
5-8 high  
up to 9 tons



**Double stacking**  
4-8 high  
up to 10 tons



MODEL NAME	CAPACITY	WHEELBASE
SMV 3 ECB 80	8 tons at 1220 mm	3750 mm
SMV 4 ECB 80	8 tons at 1220 mm	3750 mm
SMV 5 ECB 80	8 tons at 1220 mm	3750 mm
SMV 6 ECB 80	8 tons at 1220 mm	3750 mm

MODEL NAME	CAPACITY	WHEELBASE
SMV 5/6 ECB 90	9 tons at 1220 mm	4500 mm
SMV 6/7 ECB 90	9 tons at 1220 mm	4500 mm
SMV 7/8 ECB 90	9 tons at 1220 mm	4500 mm

MODEL NAME	CAPACITY	WHEELBASE
SMV 4/5 ECB 100 DS*	10 tons at 1220 mm	4500 mm
SMV 5/6 ECB 100 DS*	10 tons at 1220 mm	4500 mm
SMV 6/7 ECB 100 DS*	10 tons at 1220 mm	4500 mm

\*DS = double-stacking spreader

## Laden container handlers

**Low cabin**  
3-4 high  
33-35 tons



MODEL NAME	CAPACITY	WHEELBASE
SMV 37 G3-G4	35/33 tons at 1490/1730 mm	5000 mm

**High/mid cabin**  
4 high  
33-35 tons



MODEL NAME	CAPACITY	WHEELBASE
SMV 37 G4S	35/33 tons at 1490/1730 mm	5000 mm

**Low cabin**  
3-4 high  
41-45 tons



MODEL NAME	CAPACITY	WHEELBASE
SMV 45 G3-G4	43/41 tons at 1490/1730 mm	5500 mm
SMV 52 G3-G4	45/43 tons at 1490/1730 mm	6000 mm

**High/mid cabin**  
4-5 high  
41-45 tons



MODEL NAME	CAPACITY	WHEELBASE
SMV 45 G4S-G5S	42/41 tons at 1490/1730 mm	5500 mm
SMV 52 G4S-G5S	45/43 tons at 1490/1730 mm	6000 mm

# DIMENSION MEASUREMENT IDENTIFIERS

Empty container lift trucks

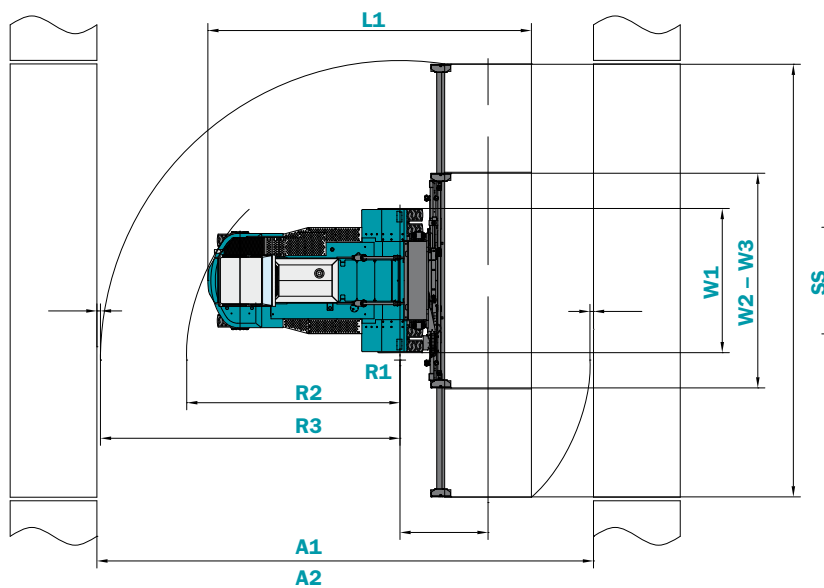
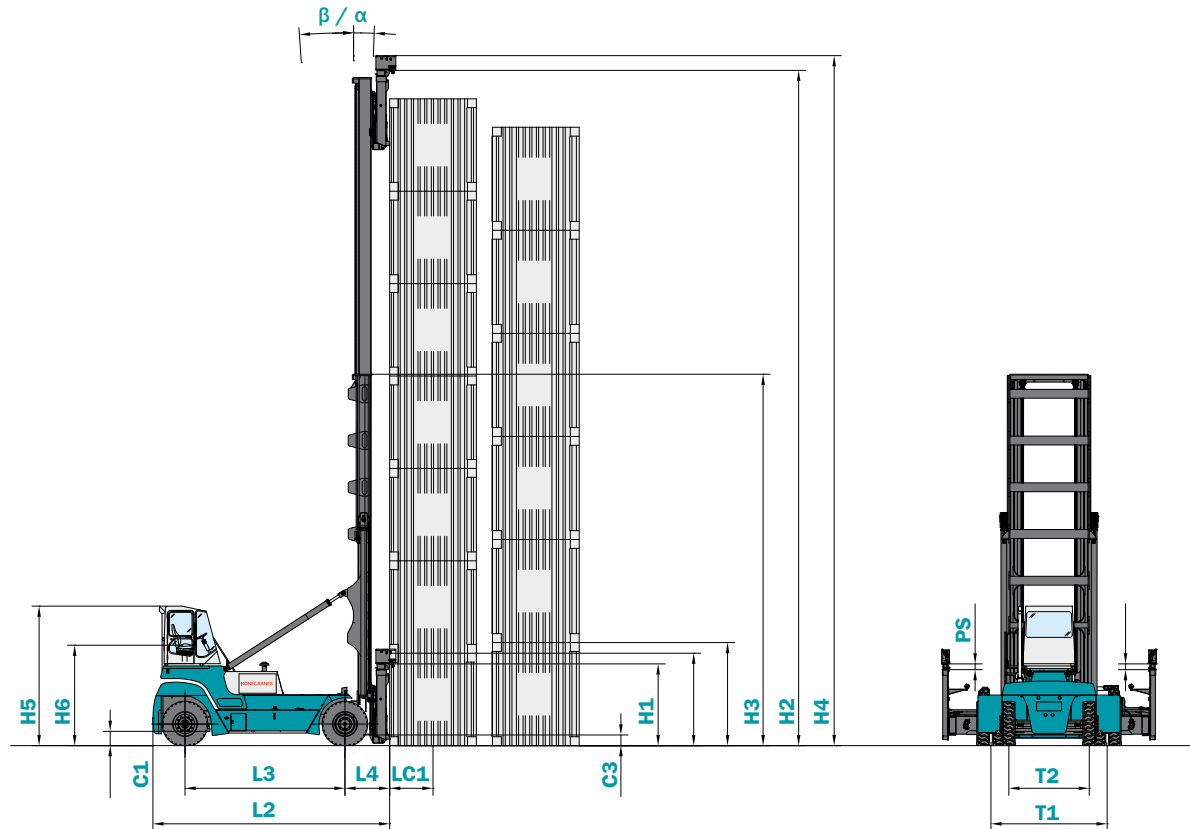



Laden container lift trucks

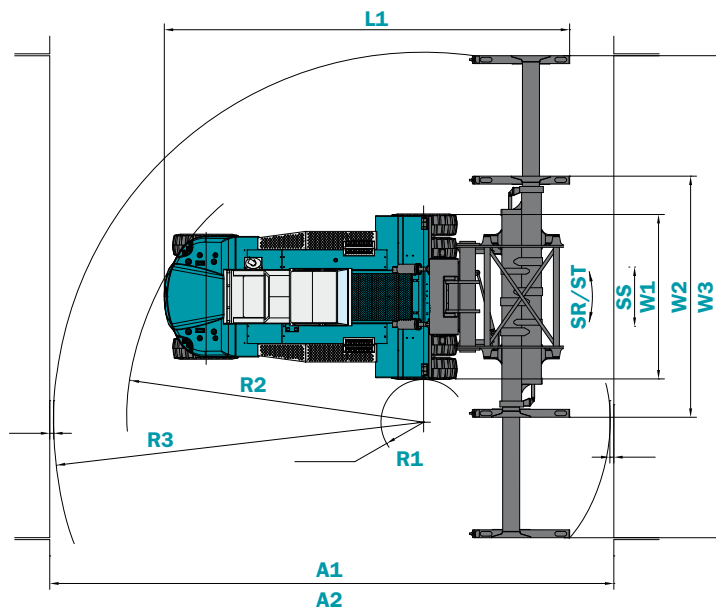
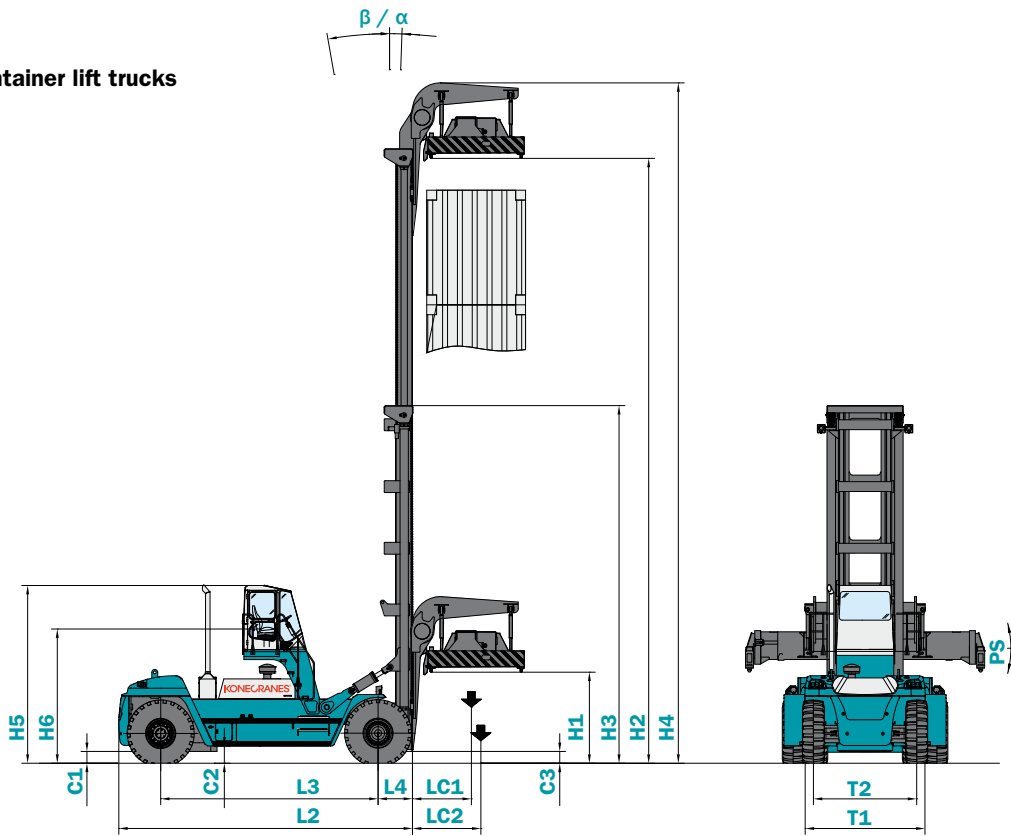

# TECHNICAL DATA

Empty container lift trucks, 8 – 10 tons

MODEL			SMV 3 ECB 80	SMV 4 ECB 80	SMV 5 ECB 80	SMV 6 ECB 80	
LIFTING DATA	<b>Dimensions</b>	<b>Identifier</b>	<b>Units</b>				
	Lifting capacity / load center	<b>LC1</b>	kg/mm	8000 / 1220	8000 / 1220	8000 / 1220	8000 / 1220 (up to 5 high)
	Stacking height, single mode (9'6" / 8'6")			3 x 9'6" / 3 x 8'6"	4 x 9'6" / 4 x 8'6"	5 x 9'6" / 5 x 8'6"	5 x 9'6" / 6 x 8'6"
	Stacking height, double mode (9'6" / 8'6")			-	-	-	-
	Spreader type, telescopic, locking			Vertical twistlocks, 20-40 ft, safety locking, LED lamps			
	Lost load center	<b>L4</b>	mm	1095	1095	1095	1095
Wheelbase	<b>L3</b>	mm	3750	3750	3750	3750	
WEIGHT	Service weight		kg	26900	28000	28800	29000
	Axle pressure front, unloaded / at rated load		kg	14600 / 27500	15700 / 28600	16700 / 29600	17000 / 26700
	Axle pressure rear, unloaded / at rated load		kg	12300 / 7400	12300 / 7400	12100 / 7200	12000 / 8300
WHEELS	Tire type			Pneumatic	Pneumatic	Pneumatic	Pneumatic
	Tire dimensions / ply rating, front & rear		Inch	12.00 x 20" / PR 20	12.00 x 20" / PR 20	12.00 x 20" / PR 20	12.00 x 20" / PR 20
	Rim dimensions, front & rear		Inch	8.00 x 20"	8.00 x 20"	8.00 x 20"	8.00 x 20"
	Tire pressure, front / rear		MPa	1.0 / 1.0	1.0 / 1.0	1.0 / 1.0	1.0 / 1.0
	Number of wheels, front / rear (X = driven)			4X / 2	4X / 2	4X / 2	4X / 2
	Track width, front / rear	<b>T1 / T2</b>	mm	2843 / 2036	2843 / 2036	2843 / 2036	2843 / 2036
DIMENSIONS	Mast tilt, backward / forward	<b>β / α</b>	deg	2 / 4	2 / 4	2 / 4	2 / 4
	Lifting height, min - max	<b>H1 - H2</b>	mm	2255 - 9170	2255 - 11920	2255 - 14920	2255 - 16020
	Mast height, retracted / extended	<b>H3 - H4</b>	mm	5145 / 9490	6520 / 12240	8020 / 15240	8570 / 16340
	Truck height over cabin / seat height	<b>H5 - H6</b>	mm	2905 - 1815	3780 - 2680	3780 - 2680	3780 - 2680
	Overall length, incl. spreader / container	<b>L1 - L2</b>	mm	8080 - 5640	8080 - 5640	8080 - 5640	8080 - 5640
	Drive axle width	<b>W1</b>	mm	2500	3530	3530	3530
	Spreader width, min - max	<b>W2 - W3</b>	mm	6085 - 12220	6085 - 12220	6085 - 12220	6085 - 12220
	Spreader sideshift	<b>SS</b>	mm	± 300	± 300	± 300	± 300
	Mechanical Pile Slope (side tilt / no power)	<b>PS</b>	mm	0 - 200	0 - 200	0 - 200	0 - 200
	Ground clearance, mast / steering axle	<b>C1 / C3</b>	mm	250 / 200	250 / 200	250 / 200	250 / 200
	Aisle width (with 20 ft / 40 ft container)	<b>A1 / A2</b>	mm	8965 / 13700	8965 / 13700	8965 / 13700	8965 / 13700
Turning radius, inner	<b>R1</b>	mm	100 (±100)	100 (±100)	100 (±100)	100 (±100)	
Turning radius, outer 20 ft / outer 40 ft	<b>R2 / R3</b>	mm	5055 / 7985	5055 / 7985	5055 / 7985	5055 / 7985	
PERFORMANCE	Drive speed forward, unloaded / at rated load		km/h	25 / 25	25 / 25	25 / 25	25 / 25
	Drive speed reverse, unloaded / at rated load		km/h	25 / 25	25 / 25	25 / 25	25 / 25
	Lifting speed, unloaded / at 70% of rated load		m/s	0.52 / 0.45	0.52 / 0.45	0.52 / 0.45	0.52 / 0.45
	Lowering speed, unloaded / at rated load		m/s	0.55 / 0.58	0.55 / 0.58	0.55 / 0.58	0.55 / 0.58
	Gradeability, at rated load, 0/2 km/h		% / %	26 / 22	26 / 22	26 / 22	26 / 22
Towing power, at rated load, 0/2 km/h		kN / kN	107 / 85	107 / 85	107 / 85	107 / 85	
DRIVELINE	Engine power (min - max)	<b>EU2 / EU3b</b>	kW	147 - 201	147 - 201	147 - 201	147 - 201
	Engine torque (min - max)	<b>EU2 / EU3b</b>	Nm	700 - 1180	700 - 1180	700 - 1180	700 - 1180
	Transmission, gears forward + reverse			DANA 3+3 / ZF 3+3	DANA 3+3 / ZF 3+3	DANA 3+3 / ZF 3+3	DANA 3+3 / ZF 3+3
	Transmission type, function, shifting			Fully automatic, torque convertor, reverse protection, powershift			
	Drive axle model			Kessler D81 with differential			
	Driving brake system, type			Oil-cooled multiple wet disk brakes (WDB)			
Parking brake system, type			Dry single disc / spring release				
Steering system / steering axle type			Hydraulic power steering / HD axle with double-acting cylinder				
OTHERS	Load-sensing hydraulics / power-on-demand			Yes / yes	Yes / yes	Yes / yes	Yes / yes
	Hydraulic oil pressure, mast / spreader		MPa	22 / 15	22 / 15	23 / 15	24 / 15
	Diesel / hydraulic tank volumes		Lit	243 / 272	243 / 272	243 / 272	243 / 272
	Noise level inside cab (LM) DIN 45635	<b>EU2 / EU3b</b>	dB(A)	68 / 66	68 / 66	68 / 66	68 / 66
	Noise level inside cab (LpAZ) EN 12053		dB(A)	72	72	72	72
Noise level outside (LWA) 2000/14/EC		dB(A)	109	109	109	109	

NOTE 1. Other capacities available upon request

NOTE 2. Additional container stops can be provided at 24 ft, 30 ft and 35 ft (only for single-stacking)

NOTE 3. For models ECB 90–100, Hydraulic Pile Slope ±6 deg and increased sideshift to ±600 mm are available

NOTE 4. For models ECB 90, 14.00 x 24" / PR 24 tires are available

NOTE 5. For available driveline combinations, see the driveline chart and the latest factory information

NOTE 6. SMV 6 ECB 80 lifts 8000 kg up to 5 high and 6000 kg up to 6 high

SMV 5/6 ECB 90	SMV 6/7 ECB 90	SMV 7/8 ECB 90	SMV 4/5 ECB 100 DS	SMV 5/6 ECB 100 DS	SMV 6/7 ECB 100 DS
9000 / 1220	9000 / 1220	9000 / 1220	10000 / 1220	10000 / 1220	10000 / 1220
5 x 9'6" / 6 x 8'6"	6 x 9'6" / 7 x 8'6"	7 x 9'6" / 8 x 8'6"	4 x 9'6" / 5 x 8'6"	5 x 9'6" / 6 x 8'6"	6 x 9'6" / 7 x 8'6"
-	-	-	1+4 x 9'6" / 1+5 x 8'6"	1+5 x 9'6" / 1+6 x 8'6"	1+6 x 9'6" / 1+7 x 8'6"
Vertical twistlocks, 20-40 ft, safety locking, LED lamps			Lift hooks & hydr. side clamps, 20-40 ft, safety locking, LED lamps		
1195	1195	1195	1255	1255	1255
4500	4500	4500	4500	4500	4500
34500	36400	38400	36200	37500	39500
21800 / 35600	23100 / 36900	24500 / 38300	21400 / 36900	22800 / 38300	24200 / 39700
12700 / 7900	13300 / 8500	13900 / 9100	14800 / 9300	14700 / 9200	15300 / 9800
Pneumatic	Pneumatic	Pneumatic	Pneumatic	Pneumatic	Pneumatic
12.00 x 24" / PR 20	12.00 x 24" / PR 20	12.00 x 24" / PR 20	14.00 x 24" / PR 24	14.00 x 24" / PR 24	14.00 x 24" / PR 24
10.00 x 24" / HD	10.00 x 24" / HD	10.00 x 24" / HD	10.00 x 24" / HD	10.00 x 24" / HD	10.00 x 24" / HD
0.9 / 0.9	0.9 / 0.9	0.9 / 0.9	0.9 / 0.9	0.9 / 0.9	0.9 / 0.9
4X / 2	4X / 2	4X / 2	4X / 2	4X / 2	4X / 2
3270 / 2262	3270 / 2262	3270 / 2262	3286 / 2290	3286 / 2290	3286 / 2290
2 / 4	2 / 4	2 / 4	2 / 4	2 / 4	2 / 4
2245 - 16325	2245 - 18925	2245 - 21525	2310 - 13870	2310 - 16470	2310 - 19070
9130 / 16645	10430 / 19245	11730 / 21845	7890 / 14510	9190 / 17110	10490 / 19710
3900 - 2800	3900 - 2800	3900 - 2800	3965 - 2865	3965 - 2865	3965 - 2865
9045 - 6600	9045 - 6600	9045 - 6600	9100 - 6660	9100 - 6660	9100 - 6660
4060	4060	4060	4100	4100	4100
6085 - 12220	6085 - 12220	6085 - 12220	6565 - 12700	6565 - 12700	6565 - 12700
± 300	± 300	± 300	± 300	± 300	± 300
0 - 200	0 - 200	0 - 200	0 - 200	0 - 200	0 - 200
280 / 325	280 / 325	280 / 325	345 / 390	345 / 390	345 / 390
9925 / 13920	9925 / 13920	9925 / 13920	9980 / 13960	9980 / 13960	9980 / 13960
200 (±100)	200 (±100)	200 (±100)	200 (±100)	200 (±100)	200 (±100)
6000 / 8420	6000 / 8420	6000 / 8420	6000 / 8420	6000 / 8420	6000 / 8420
25 / 25	25 / 25	25 / 25	25 / 25	25 / 25	25 / 25
25 / 25	25 / 25	25 / 25	25 / 25	25 / 25	25 / 25
0.68 / 0.61	0.68 / 0.61	0.68 / 0.61	0.68 / 0.61	0.68 / 0.61	0.68 / 0.61
0.60 / 0.60	0.60 / 0.60	0.60 / 0.60	0.60 / 0.60	0.60 / 0.60	0.60 / 0.60
38 / 29	37 / 28	37 / 28	33 / 24	33 / 24	32 / 23
168 / 133	168 / 133	168 / 133	153 / 120	153 / 120	153 / 120
180 - 201	180 - 201	180 - 201	180 - 201	180 - 201	180 - 201
990 - 1180	990 - 1180	990 - 1180	990 - 1180	990 - 1180	990 - 1180
DANA 3+3 / ZF 4+3	DANA 3+3 / ZF 4+3	DANA 3+3 / ZF 4+3	DANA 3+3 / ZF 4+3	DANA 3+3 / ZF 4+3	DANA 3+3 / ZF 4+3
Yes / yes	Yes / yes	Yes / yes	Yes / yes	Yes / yes	Yes / yes
17 / 15	17.5 / 15	18.5 / 15	17.5 / 15	18.5 / 15	19.5 / 15
400 / 430	400 / 430	400 / 430	400 / 430	400 / 430	400 / 430
70 / 68	70 / 68	70 / 68	70 / 68	70 / 68	70 / 68
75	73 - 75	75	75	75	75
110	110	110	110	110	110

This publication is for general informational purposes only. Konecranes reserves the right at any time, without notice, to alter or discontinue the products and/or specifications referenced herein. This publication creates no warranty on the part of Konecranes, express or implied, including but not limited to any implied warranty or merchantability or fitness for a particular purpose.



# TECHNICAL DATA

Laden container lift trucks, 33 – 45 tons

MODEL			SMV 37 G3	SMV 37 G4 (G4S*)	SMV 45 G3	SMV 45 G4 (G4S*)	
LIFTING DATA	<b>Dimensions</b>	<b>Identifier</b>	<b>Units</b>				
	Lift capacity / load center	<b>LC1</b>	kg/mm	35000 / 1490	35000 / 1490	43000 / 1490	43000 / 1490
	Lift capacity / load center	<b>LC2</b>	kg/mm	33000 / 1730	33000 / 1730	41000 / 1730	41000 / 1730
	Stacking height, single mode (9'6" / 8'6")			3 x 9'6" / 3 x 8'6"	4 x 9'6" / 4 x 8'6"	3 x 9'6" / 3 x 8'6"	4 x 9'6" / 4 x 8'6"
	Spreader type, telescopic, locking			Twistlocks, 20-40 ft, safety locking		Twistlocks, 20-40 ft, safety locking	
	Lost load center	<b>L4</b>	mm	870	870	870	870
	Wheelbase	<b>L3</b>	mm	5000	5000	5500	5500
WEIGHT	Service weight		kg	60500	61700	63300	64500
	Axle pressure front, unloaded / at rated load		kg	38100 / 89600	39300 / 90800	38100 / 99600	39300 / 100800
	Axle pressure rear, unloaded / at rated load		kg	22400 / 5900	22400 / 5900	25200 / 6700	25200 / 6700
WHEELS	Tire type			Pneumatic	Pneumatic	Pneumatic	Pneumatic
	Tire dimension / ply rating, front & rear		Inch	18.00 x 25" / PR 40	18.00 x 25" / PR 40	18.00 x 25" / PR 40	18.00 x 25" / PR 40
	Rim dimensions, front & rear		Inch	13.00 x 25"	13.00 x 25"	13.00 x 25"	13.00 x 25"
	Tire pressure, front / rear		MPa	0.9 / 0.9	0.9 / 0.9	1.0 / 1.0	1.0 / 1.0
	Number of wheels, front / rear (X = driven)			4X / 2	4X / 2	4X / 2	4X / 2
	Track width, front / rear	<b>T1 / T2</b>	mm	3030 / 2612	3030 / 2612	3030 / 2612	3030 / 2612
DIMENSIONS	Mast tilt, backward / forward	<b>β / α</b>	deg	2 / 10	2 / 10	2 / 10	2 / 10
	Lifting height, min - max	<b>H1 - H2</b>	mm	2300 - 9500	2300 - 12400	2300 - 9500	2300 - 12400
	Mast height, retracted / extended	<b>H3 - H4</b>	mm	6150 / 11400	7600 / 14300	6150 / 11400	7600 / 14300
	Truck height over cabin / seat height	<b>H5 - H6</b>	mm	3660 - 2560	3660 - 2560 (4500 - 3400)	3660 - 2560	3660 - 2560 (4500 - 3400)
	Overall length, incl. spreader / container	<b>L1 - L2</b>	mm	6930 - 9760	6930 - 9760	7430 - 10250	7430 - 10250
	Drive axle width	<b>W1</b>	mm	4160	4160	4160	4160
	Spreader width, min - max	<b>W2 - W3</b>	mm	6050 - 12175	6050 - 12175	6050 - 12175	6050 - 12175
	Spreader sideshift	<b>SS</b>	mm	± 200	± 200	± 200	± 200
	Spreader reach in - out	<b>SR</b>	mm	0 - 240	0 - 240	0 - 240	0 - 240
	Spreader turn left / right	<b>ST</b>	deg	± 6	± 6	± 6	± 6
	Mechanical Pile Slope (side tilt / no power)	<b>PS</b>	deg	± 5	± 5	± 5	± 5
	Ground clearance, mast / mid / steering axle	<b>C1 / C2 / C3</b>	mm	300 / 440 / 270	300 / 440 / 270	300 / 440 / 270	300 / 440 / 270
	Aisle width (with 20 ft / 40 ft container)	<b>A1 / A2</b>	mm	10900 / 14200	10900 / 14200	11400 / 14300	11400 / 14300
Turning radius, inner	<b>R1</b>	mm	< 750	< 750	< 1100	< 1100	
Turning radius, outer 20 ft / outer 40 ft	<b>R2 / R3</b>	mm	6900 / 9000	6900 / 9000	7500 / 9350	7500 / 9350	
PERFORMANCE	Drive speed forward, unloaded / at rated load		km/h	24 / 22	24 / 22	24 / 22	24 / 22
	Drive speed reverse, unloaded / at rated load		km/h	24 / 22	24 / 22	24 / 22	24 / 22
	Lifting speed, unloaded / at rated load		m/s	0.26 / 0.21	0.26 / 0.21	0.26 / 0.21	0.26 / 0.21
	Lowering speed, unloaded / at rated load		m/s	0.40 / 0.40	0.40 / 0.40	0.40 / 0.40	0.40 / 0.40
	Gradeability, at rated load, 0/2 km/h		% / %	29 / 22	29 / 22	29 / 22	29 / 22
	Towing power, at rated load, 0/2 km/h		kN / kN	315 / 251	315 / 251	315 / 251	315 / 251
DRIVELINE	Engine power (min - max)	<b>EU2 / EU3b</b>	kW	256 - 294	256 - 294	256 - 294	256 - 294
	Engine torque (min - max)	<b>EU2 / EU3b</b>	Nm	1640 - 2172	1640 - 2172	1640 - 2172	1640 - 2172
	Transmission, gears forward + reverse			DANA 4+4 / ZF 4+3	DANA 4+4 / ZF 4+3	DANA 4+4 / ZF 4+3	DANA 4+4 / ZF 4+3
	Transmission type, function, shifting			Automatic, torque convertor, reverse protection, powershift			
	Drive axle model			Kessler D102 with differential			
	Driving brake system, type			Oil-cooled multiple wet disk brakes (WDB)			
	Parking brake system, type			Dry single disc / spring release			
Steering system / steer axle type			Hydraulic power steering / HD axle + double-acting cylinder				
OTHERS	Load-sensing hydraulics / power-on-demand			Yes / yes	Yes / yes	Yes / yes	Yes / yes
	Hydraulic oil pressure, mast/spreader		MPa	21 / 15	21 / 15	22 / 15	23 / 15
	Diesel / hydraulic tank volumes		L	410 / 480	410 / 480	510 / 550	510 / 550
	Noise level inside cab (LM) DIN 45635	<b>EU2 / EU3b</b>	dB(A)	73 / 71	73 / 71	73 / 71	73 / 71
	Noise level inside cab (LpAZ) EN 12053		dB(A)	75	75	75	75
Noise level outside (LWA) 2000/14/EC		dB(A)	111	111	111	111	

NOTE 1. Other capacities available upon request

NOTE 2. Increased sideshift to ±400 mm is available

NOTE 3. Container guides on one side of spreader are also available

NOTE 4. Four lifting eyes on spreader are standard; extra ones are available

NOTE 5. Additional container stops can be provided at 24 ft, 30 ft and 35 ft (only for single-stacking)

NOTE 6. For available driveline combinations, see the driveline chart and the latest factory information

SMV 45 G5S	SMV 52 G3	SMV 52 G4 (G4S*)	SMV 52 G5S
42000 / 1490	45000 / 1490	45000 / 1490	45000 / 1490
41000 / 1730	43000 / 1730	43000 / 1730	43000 / 1730
5 x 9'6" / 5 x 8'6"	3 x 9'6" / 3 x 8'6"	4 x 9'6" / 4 x 8'6"	5 x 9'6" / 5 x 8'6"
Twistlocks, 20-40 ft, safety locking			
870	970	970	970
5500	6000	6000	6000
67500	64300	66500	69500
42300 / 102400	39800 / 107500	41000 / 107500	44000 / 107500
25200 / 7100	25500 / 6600	25500 / 6600	25500 / 7000
Pneumatic	Pneumatic	Pneumatic	Pneumatic
18.00 x 25" / PR 40	18.00 x 33" / PR 36	18.00 x 33" / PR 36	18.00 x 33" / PR 36
13.00 x 25"	13.00 x 33"	13.00 x 33"	13.00 x 33"
1.0 / 1.0	1.0 / 1.0	1.0 / 1.0	1.0 / 1.0
4X / 2	4X / 2	4X / 2	4X / 2
3030 / 2612	3030 / 2612	3030 / 2612	3030 / 2612
2 / 10	2 / 10	2 / 10	2 / 10
2300 - 15300	2300 - 9500	2300 - 12400	2300 - 15300
9050 / 17200	6300 / 11400	7700 / 14300	9220 / 17200
4500 - 3400	3860 - 2780	3860 - 2780 (4700 - 3600)	4700 - 3600
7430 - 10250	8100 - 10950	8100 - 10950	8100 - 10950
4160	4160	4160	4160
6050 - 12175	6050 - 12175	6050 - 12175	6050 - 12175
± 200	± 6	± 6	± 6
0 - 240	0 - 240	0 - 240	0 - 240
± 6	± 6	± 6	± 6
± 5	± 5	± 5	± 5
300 / 440 / 270	470 / 600 / 400	470 / 600 / 400	470 / 600 / 400
11400 / 14300	12000 / 14400	12000 / 14400	12000 / 14400
< 1100	< 1200	< 1200	< 1200
7500 / 9350	8050 / 9400	8050 / 9400	8050 / 9400
24 / 22	25 / 22	25 / 22	25 / 22
24 / 22	25 / 22	25 / 22	25 / 22
0.26 / 0.21	0.26 / 0.21	0.26 / 0.21	0.26 / 0.21
0.40 / 0.40	0.40 / 0.40	0.40 / 0.40	0.40 / 0.40
29 / 22	34 / 22	34 / 22	34 / 22
315 / 251	260 / 214	260 / 214	260 / 214
256 - 294	256 - 294	256 - 294	256 - 294
1640 - 2172	1640 - 2172	1640 - 2172	1640 - 2172
4 / 4 or 4 / 3	4 / 4 or 4 / 3	4 / 4 or 4 / 3	4 / 4 or 4 / 3
Automatic, torque convertor, reverse protection, powershift			
Kessler D106 with differential			
Oil-cooled multiple wet disk brakes (WDB)			
Dry single disc / spring release			
Hydraulic power steering / HD axle + double-acting cylinder			
Yes / yes	Yes / yes	Yes / yes	Yes / yes
24 / 15	22 / 15	24 / 15	24 / 15
510 / 550	550 / 620	550 / 620	550 / 620
73 / 71	73 / 71	73 / 71	73 / 71
75	75	75	75
111	111	111	111



INDUSTRIAL  
CRANES



NUCLEAR  
CRANES



PORT  
CRANES



HEAVY-DUTY  
LIFT TRUCKS



SERVICE



MACHINE  
TOOL  
SERVICE



Konecranes is a world-leading group of Lifting Businesses™ offering lifting equipment and services that improve productivity in a wide variety of industries. The company is listed on NASDAQ OMX Helsinki Ltd (symbol: KCR1V). With over 12,000 employees at more than 600 locations in almost 50 countries we have the resources, technology and determination to deliver on the promise of Lifting Businesses™.

© 2013 Konecranes. All rights reserved. "Konecranes", "Lifting Businesses" and  are registered trademarks of Konecranes.



**Konecranes Liftrucks AB** Box 103, SE-285 23 Markaryd, Sweden  
Tel. +46 433 73300, Fax +46 433 73310, E-mail: [info.liftrucks@konecranes.com](mailto:info.liftrucks@konecranes.com)  
[www.konecranesliftrucks.se](http://www.konecranesliftrucks.se) [www.konecranes.com](http://www.konecranes.com)